

The reflexion and diffraction of shock waves

By D. C. PACK

Department of Mathematics, The Royal College of Science and Technology,
Glasgow

(Received 12 June 1963)

1. Introduction

When I was first asked to give a general lecture to the 5th British Theoretical Mechanics Colloquium (held at Liverpool University, 2–5 April 1963), I put up the title ‘Shock Waves’, thinking that I might run over a wide field of present-day research, pointing out some of the unanswered problems. In the intervening months, however, I came across the new book by Dr Bradley (1962) of Liverpool University, *The Physics and Chemistry of Shock Waves*, and as recently as last November there appeared a summarizing article by Pain & Rogers (1962) of London University in *Reports on Progress in Physics*. The first of these deals in great detail with the modern physical and chemical aspects of the subject—with real gas effects and experimental techniques—and the second summarizes the general classical properties and gives an extended account of recent work, for example, on real gas effects and on magnetohydrodynamics. I also bore in mind that magnetogasdynamics received a majestic treatment at the 4th Colloquium from Dr Shercliff. In the end, then, I decided to confine my remarks to one particular problem, namely the reflexion and diffraction of shock waves, and to concentrate mainly on developments during the past ten years. This paper is the text of the lecture.

Experimentally, in the laboratory, there are two ways in which shock reflexion may be studied. Shocks may reflect off one another, or they may reflect off surfaces. If two shocks of equal strength reflect off one another their interaction is equivalent to the reflexion of a shock from a rigid boundary neglecting boundary-layer effects. The first experimental work on shock waves, carried out by Ernst Mach and his associates in the 1870’s, was of this kind. Reflexion off solid walls is usually studied in a shock tube, and it is interesting to note that this instrument was invented as long ago as 1899 by Vieille, a French scientist, so that the tools for the investigation of this subject were available before the turn of last century. It was not, however, until the last war that the subject got thoroughly under way, and it continues to provide some challenging problems both for the theoretical and experimental worker.

2. Normal reflexion

The simplest possible example of a reflexion is that of a shock hitting a rigid wall head-on. The boundary condition is that the gas adjacent to the wall stays at rest. Application of the Rankine–Hugoniot equations shows that, for an ideal

gas, with $\gamma = 1.4$, for example, the multiplication factor for the pressure in the incident wave can be as great as 8. This fact has been put to good experimental use for the study of the properties of gases at high temperatures. Bradley (1962) quotes the example of a shock-tube diaphragm pressure ratio of 95 with helium as the driving gas producing a reflected shock temperature in argon of 4000 °K. A diaphragm pressure ratio of 1600 would be required to produce the same temperature rise in the incident shock. Then again, by choosing a reaction that occurs rapidly at high temperatures, the shock reflexion can be utilized to create detonation, and the initiation of this can be studied at the far end of the tube (see, for example, Strehlow & Cohen 1962). Herzberg and others have employed the high-pressure property to create hypersonic nozzle flow out of the end of a shock tube. The flow is not usually 'ideal' under these circumstances, particularly if there are long relaxation times in the gas, and I shall have something to say later about the effect of the lateral boundary layers on the reflexion properties.

An interesting refinement of the reflexion problem has been given by Goldsworthy (1959) for his treatment of the reflexion of a shock wave from a heated wall. The effect of the heat is to create, behind the reflected shock, a contact discontinuity separating heated from unheated gas. It is supposed that at time $t = 0$ a plane shock of given strength is reflected from a wall at initial temperature T_1 . The temperatures in the wall and in the gas are found subject to the temperatures being T_1 at the edge of the contact region in the wall and T_3 determined by inviscid theory at the edge of the contact region in the gas. The temperature and the flux of heat are continuous at the wall. From the temperature distribution, the velocity distribution in the gas is determined by using the condition that the particle velocity must be zero at the wall. To find the pressure of the gas in this region it is necessary to calculate the perturbed flow external to the contact region. The perturbation is small when the shock is at a distance from the wall much greater than the molecular mean free path. The problem reduces to that of solving the wave equation with the boundary condition for the velocity $u = u_\infty$ at the edge of the contact region linearized by applying it at the wall. It is found that the perturbation to the reflected shock speed varies inversely as the square root of the time.

The reflexion of a normal shock wave at the interface between two media involves the transmission of a shock wave; the nature of the reflected wave is governed by the ratio of the shock impedances across the interface, the shock impedance of a medium being defined as the product of the equilibrium density and the speed of the shock wave moving downstream through it. A shock wave is always reflected from a medium of greater shock impedance. This criterion is very simple, but unfortunately one does not *know* the speed of the *transmitted* shock until the whole phenomenon has been determined. For gases it has been known for a long time (Paterson 1948) that, *in general*, the ratio of *acoustic* impedances is decisive, where, to compute the acoustic impedance, one substitutes the speed of sound for the shock velocity.

It has been shown (Pack 1957*a*) that for the reflexion of a detonation wave, with detonation products treated as an ideal gas with a constant ratio of specific

heats γ , a very simple rule can be obtained, namely that the reflexion is a rarefaction or a shock wave according as

$$(\gamma + 1) (\rho_0/r_0) \{1 - (r_0/r_1)\} > \text{ or } < 1,$$

where r_1 is the density in the second medium corresponding to the passage through it of a shock wave with the pressure of the incident wave. As one might

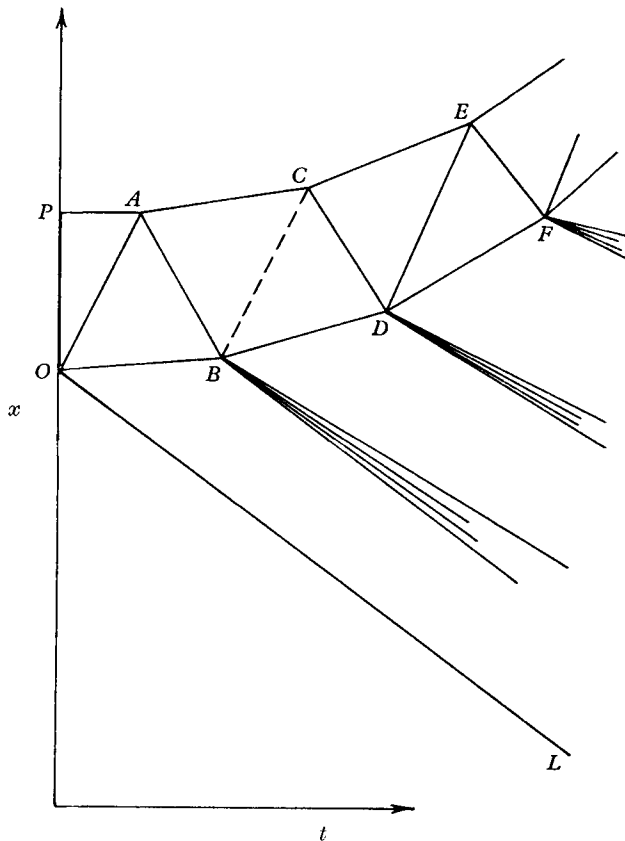

FIGURE 1. The incident shock wave strikes the target OP at O . OL is the reflected shock. The motion is one-dimensional. OBD is the path of the front face of the target and $PACE$ the path of the rear face. Time t is measured to the right (Pack 1957*b*).

expect a reflected rarefaction wave is the rule for explosives in contact with a gas or with water. For an explosive in contact with a solid a *sufficient* condition for a reflected shock is that the transmitted shock should advance with a speed greater than the speed of elastic waves. This is not always satisfied, e.g. for some explosives in contact with a steel target. Nevertheless, rough calculations suggest that a reflected shock seems likely to be the general rule. The importance of calculations of this type is in connexion with the determination of the properties of explosion products, in which for obvious reasons direct experimentation is very difficult or even impossible. It has also been used for the study of the behaviour of liquids and solids under high pressures. Measurements of the speed

of the shock transmitted through a second medium and the rate of initial motion of the rear surface when this medium is solid can be correlated with features of the incident pulse. For a uniform incident shock wave, falling upon a slab of finite thickness, the acceleration of the slab is achieved in finite jumps, as in figure 1, where the transmitted shock is supposed to be at a pressure below the elastic limit. The successive rarefactions at B , D , F , ... produce simple wave variations on the flow behind the reflected shock until such time as the first of these, reflected, reaches back to the target.

A development of this simple theory, allowing for a simple wave expansion of the detonation products but neglecting entropy changes, was used for example by Ablow (1960) to compute an effective ratio of specific heats for an explosive composition. Modern methods of measurement involving pressure transducers seem likely to make it possible to follow events inside certain suitable materials with considerable precision, allowing much more detailed deductions to be made from experimental results. This kind of work proceeds often on the basis of quite crude assumptions about equations of state, but many very important results have come from these efforts.

3. Oblique reflexion

In natural phenomena normal reflexion is, of course, a very special circumstance. There is usually some angle of inclination between a shock and another shock or a body upon which it impinges. Two kinds of problem emerge. The first, that of *stationary flow*, arose in Mach's work on supersonic jets, which led to patterns still not entirely understood. The first comprehensive observations on freely intersecting shocks in stationary flow were carried out in the United Kingdom by Lean (1943, 1946), who studied the flow between wedges placed in a wind-tunnel. During the last war the shock tube was used extensively for investigations of the reflexion and diffraction of shock waves by a solid obstacle, on account of the importance of this subject in assessing the effect of blast waves. The experiments of L. G. Smith (1945) are probably the most-quoted. In this work a shock wave, moving down the tube, struck a wedge fixed in the tube. The reflected shock pattern, originating at the apex of the wedge, began to develop uniformly with time. This illustrated the second type of problem, that of *pseudo-stationary flow*. The theory of shock wave reflexion, on the basis of straight shocks meeting at a point and separated by regions of uniform flow, has been examined exhaustively by Polachek & Seeger (1949).

3.1. Regular reflexion

The simplest configuration is that of *regular reflexion* and is represented in figure 2. Let the shock wave, travelling with velocity U , strike a rigid wall at an angle θ at the point O . This point moves along the wall with a velocity $U \operatorname{cosec} \theta$. By imposing an equal and opposite velocity on the whole system we are led to consider the flow of a gas through a stationary shock OI , as in the lower part of the figure. This flow is deflected through an angle ϕ (further away from the normal). Since it must end up parallel to the wall a further front is needed through the point O . This is the reflected shock wave OR . The whole motion is

equivalent to flow past successive wedges of semi-angle ϕ , as shown in the upper part of the figure. This provides a key to the understanding of possible solutions. This kind of shock pattern is only possible if the flow behind OI is supersonic and if the required deflexion through OR can be achieved with the Mach number found. For a given Mach number of the incident shock, there is a maximum

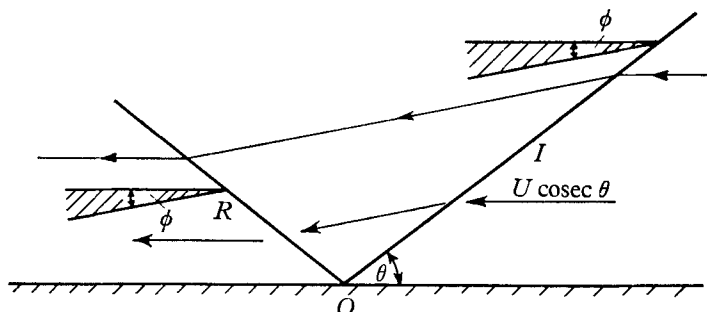

FIGURE 2. Regular reflexion at a rigid wall.

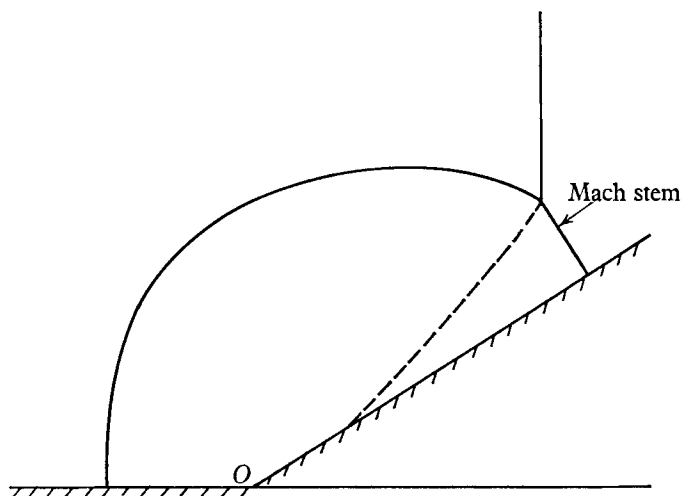

FIGURE 3. Mach reflexion in diffraction by a wedge. The case illustrated corresponds to flow past a wedge with a Mach number resulting in a detached bow shock.

angle of incidence $\theta = \theta_m$ for which regular reflexion may occur. Polachek & Seeger based their calculations on the assumption that when there are two possible shocks producing a given deflexion it is the weaker that will occur. This is an experimental fact for shocks attached to bodies in supersonic flow and is justified here by the excellent accord between theory and experiment for regular reflexions. It is significant in this respect that the simple two-shock solution, with regions of uniform flow, is a solution in both stationary and pseudo-stationary flow which satisfies the boundary conditions at the wall or plane of symmetry. I shall not go into the detailed properties of these reflexions, for which the original paper may be consulted, but will pass on to the subject of greatest interest, that of the shock pattern when regular reflexion is not possible.

3.2. Mach reflexion

When regular reflexion does not occur, the incident and reflected shocks stand off from the wall (figure 3) being joined to it by a third shock wave, often referred to as a 'Mach stem' in honour of Mach's early experiments. The gas swept up by this stem has to flow side-by-side with gas that has passed through both the incident and reflected shocks. It is therefore essential that a contact discontinuity should pass through the so-called 'triple point' of intersection of the

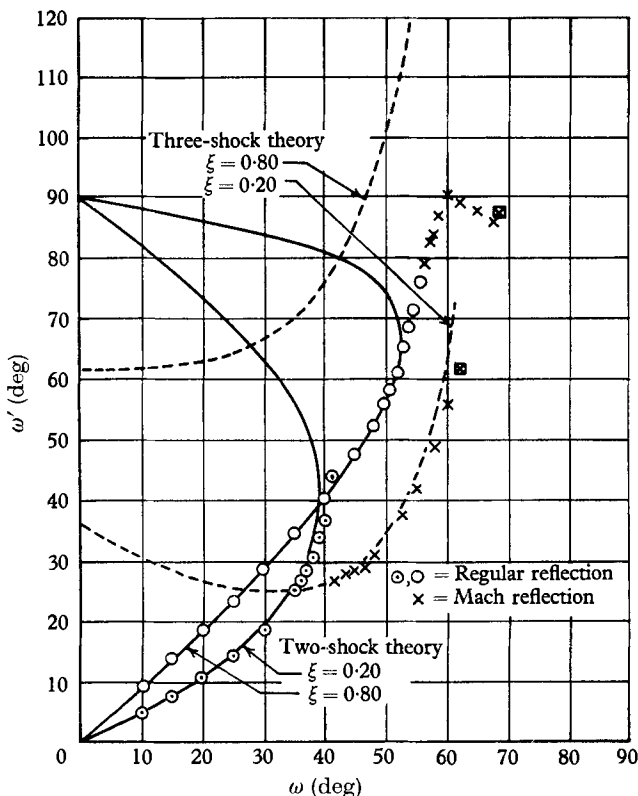

FIGURE 4. Comparison of theory and experiment in regular and Mach reflexion. ξ = ratio of pressure ahead of to the pressure behind the incident shock, ω and ω' are the angles made by the incident and reflected shocks respectively with the path of the intersection of these shocks (i.e. the path of the triple point in Mach reflexion and the wall in regular reflexion). The points enclosed in square boxes represent values of ω and ω' at which the total flow behind the incident shock is just sonic with respect to an observer moving with the triple point. There can be no solutions for ω greater than this limiting value (Bleakney & Taub 1949).

shocks. When the configuration starts at the wedge tip the triple point follows a path through this point, and the direction of motion of the point gives an additional parameter. The strength of the reflected shock in the three-shock configuration agrees tolerably with calculated results for strong incident shocks, but the experimental results differ very widely from the theoretical for weak incident shocks. Examples for values 0.8 (weak) and 0.2 (strong) of the ratio of

pressures across the incident shock are shown in figure 4. The calculations assume that near the triple point the shocks are straight, that there are regions of uniform flow between them, and that the two-dimensional unsteady flow remains geometrically similar at all times. This kind of flow, as indicated earlier, is called 'pseudo-stationary' and its solution can be described completely in terms of the 'conical' co-ordinates $x/t, y/t$.

3.3. *The transition from regular reflexion to Mach reflexion*

Until very recently it was claimed that regular reflexions were observed for angles of incidence greater than those allowed by theory (cf. figure 4). This was stated to be the case also for refraction of shocks from a gaseous interface in the work of Jahn (1957). The resolution of this difference between theory and experiment seems to have been made recently by W. R. Smith (1959). He reflected the inci-

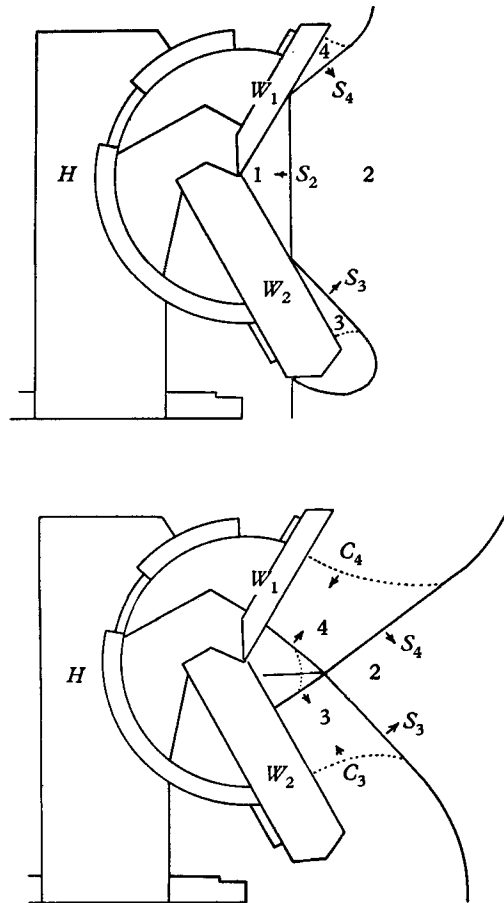

FIGURE 5. Formation of interacting shock waves of unequal strengths by reflexion of an initial shock wave from a concave corner. In the upper figure the initial shock wave S_2 reflects from the solid plate W_1 and the slotted plate W_2 held by the variable angle holder H to form the reflected shock waves S_3 and S_4 . Sonic corner signals C_3 and C_4 propagate from the ends of W_1 and W_2 . In the lower figure S_2 has disappeared, and S_3 and S_4 are interacting. The arrows indicate motions relative to the laboratory (W. R. Smith 1959).

dent shock wave S_2 against a concave corner (figure 5), the upper wall of which was a solid steel plate and the lower either a *slotted* plate (to produce unequal shocks on reflexion), or another *solid steel* plate (to produce equal shocks). Equal shocks here give the equivalent of reflexion from a solid wall without boundary-layer interference. His important findings were

- (i) that where both Mach and regular reflexion may theoretically occur for a given initial flow, only regular reflexion occurs;
- (ii) the transition from regular to Mach reflexion with increasing incidence depends on whether regular reflexion is impossible;
- (iii) the slipstreams provide the most sensitive and most conclusive proof of Mach reflexion.

Since the slipstreams were invisible in interferograms showing a decided Mach shock, he inferred that interferograms were completely useless in determining the transition between regular and Mach reflexion. Schlieren photographs and shadowgrams do show the slipstreams. Since the angle χ made by the triple point grows only slowly with increasing incidence α for reflexion of *weak waves* from a wedge, the wedge obscures the slipstream until the triple point has propagated a good way from the wedge. Smith concludes that this explanation accounts for the apparent discrepancies noted by Jahn in his work on refraction.

Experimental work has not yet been able to determine whether transition occurs at the maximum possible angle α_c or at the stage when subsonic speed begins behind the reflected shock. Theoretical comparison with flow past a wedge would suggest that the maximum angle should be the critical one, but it is difficult to differentiate experimentally between these points. Since when the shocks are unequal there are *two* sonic points, one for the flow behind each of the reflected shocks, Smith conjectured that it might be possible by a suitable choice of shocks of unequal strength to conduct a decisive experiment, but he shot his own conjecture down last year (Smith 1962) when he showed that for shocks with a ratio of strengths varying from 1 to 100, with the weaker varying between 1.1 and 10 , the sonic and extreme angles never varied by more than 1.1° .

The refraction experiments of Jahn (1956), like those of Smith, avoid the interference of a corner, so that all observed effects may be attributed to the shock intersection. Here there is an even more complex range of possibilities. The 'regular' pattern involves a transmitted shock wave, a reflected shock or rarefaction wave, and a deflexion of the interface to accommodate the pressure changes. A photograph of a regular refraction with a reflected rarefaction wave is given in figure 6. Extensive calculations for these configurations were published by Taub (1947) and by Polachek & Seeger (1951). Jahn's work provides good confirmation of their results.

In his second paper Jahn (1957) examines the transition processes more fully. He conjectures that the subsonic flow behind the reflected shock may contain singularities near the wall, because he observes a severe rarefaction zone behind the reflected shock for α just greater than α_c . Since Jahn's work was interferometric and the angle under discussion comes in the region where, according to Smith, there would be a slipstream invisible to this technique, I think we have to treat his assumption of regular reflexion with reserve. Guderley, in earlier

work, had shown the role of singularities in the description of flow past wedges with subsonic flow behind the attached shock, and he pointed out in his book (1962) that the same singular behaviour would apply near the limit of regular reflexion. Jahn (1957) drew attention to this analogy, pointing out that it had not been thought about sufficiently deeply in connexion with the understanding of Mach shocks. It was Sternberg (1959) who took up these considerations in detail.

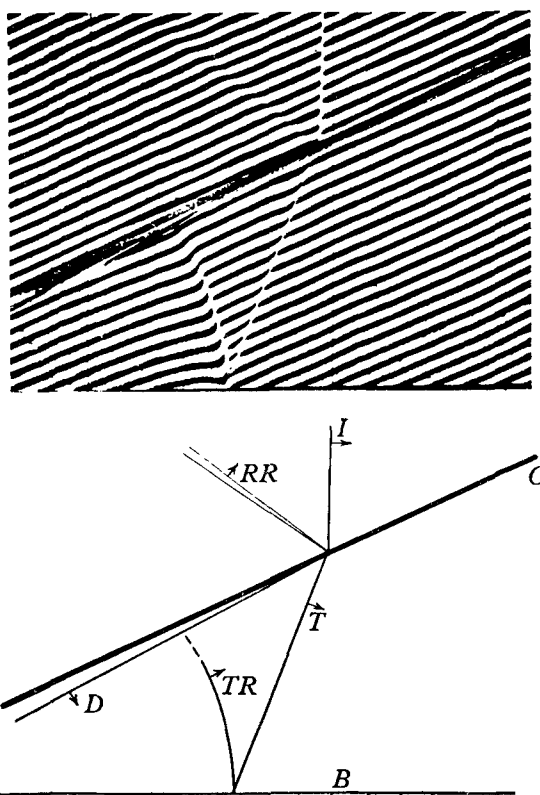

FIGURE 6. An interferogram of regular refraction at an air/CO₂ interface. I , T are the incident and transmitted shocks, RR a reflected rarefaction, O and D are the original and deflected interfaces, B the back plate and TR the reflexion of T from B (Jahn 1956).

3.4. Three-shock theories

The theory of shock polars indicates that the expected sequence of events, with increasing angle of incidence of a shock of given strength, is:

- (i) regular reflexion with supersonic flow behind the reflected shock,
- (ii) regular reflexion with subsonic flow behind the reflected shock,
- (iii) Mach reflexion with subsonic flow behind the Mach stem,
- (iv) no intersection of shock polars in the subsonic domain.

For case (iv) Guderley (1962) suggested that a reflected shock be fitted in to give just subsonic flow, followed by an expansion wave of Prandtl–Meyer type. This kind of flow can be uniquely determined. In figures 7 and 8 flows of types (iii) and (iv) are represented in both the hodograph and physical planes. The existence

of these flows has been questioned on the grounds that they require the reflected shock to point upstream at the triple point. Experimentally they have not been fully substantiated, for although angles of greater than 90° have been reported by experimenters, this has not yet occurred under circumstances entirely free from criticism. The region of Mach reflexion divides into three parts, according as the point indicating the reflected shock lies in the supersonic region, between the sonic point and the Crocco point, or between the Crocco point and the point of maximum deflexion on the shock polar. The types are as drawn in figure 9. On a shock polar, as Busemann showed many years ago, the streamline directions in the hodograph plane are determined in advance. At the intersection of two shock polars it is therefore a coincidence if these directions are compatible. If they are not, then some kind of singularity is necessary. The work of Clutterham

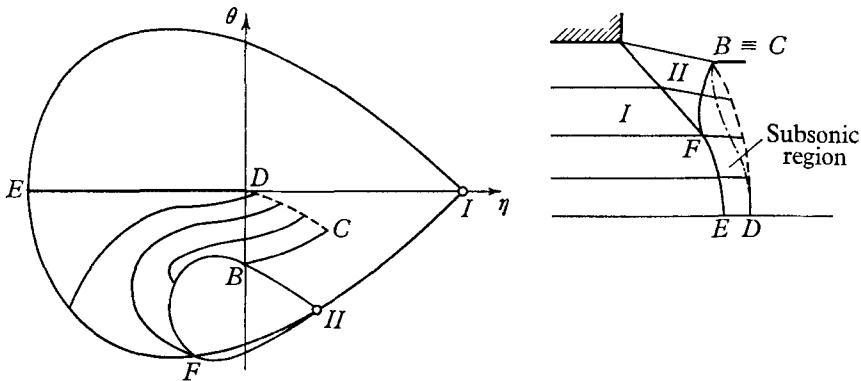

FIGURE 7. Hodograph representation with shock polars for the jet flow in the physical plane illustrated on the right. BD is the sonic line, BC is a characteristic representing a Prandtl-Meyer expansion point-localized at B in the physical plane. η is a speed variable representing departure from sonic speed: $\eta > 0$ for supersonic speed, $\eta < 0$ for subsonic. θ represents the inclination of the flow to the incident stream in region I (point I of the hodograph plane) (Guderley 1962).

& Taub (1956) gave for the angle χ of the path of the slipstream in pseudo-stationary flow, $\chi = \alpha + \tau(\xi)$, where α is the angle of incidence and $\tau(\xi)$ a function of ξ , the strength of the incident shock. Thus, for a shock of given strength, $\partial\chi/\partial\alpha = 1$. This result, contradicted by experiment, must fail whenever the shock wave topology at the triple point is not analytic, analyticity being assumed in the theory. The streamline contradictions are indicated by the arrows in the right-hand parts of figure 9. These, illustrated here on shock-polars in the (p, θ) -plane, are resolved by singularities in such a way that if the streamlines converge at the point of intersection the shock curvature K_s in the physical plane tends to infinity, while if they diverge $K_s \rightarrow 0$. At low supersonic Mach numbers the intersections fall in subsonic parts of both shock polars. For $M > 3.2$ the intersections may fall on the supersonic portion of the reflected shock polar. At high Mach numbers the sequence of events is that, when Mach reflexion starts, the intersections are of type C. For this type there is no curvature at the triple point, which presumably accounts for the agreement with theory. As the incidence increases there is a set of group B. The curvature is again zero, the conditions

behind the reflected shock corresponding to a point between the sonic and Crocco points. Then come group A intersections extending to incident shock waves close to the extreme angle. For these, the curvature is infinite. These are the *only* types possible for shocks with incident Mach number $M < 3.2$, not such a low

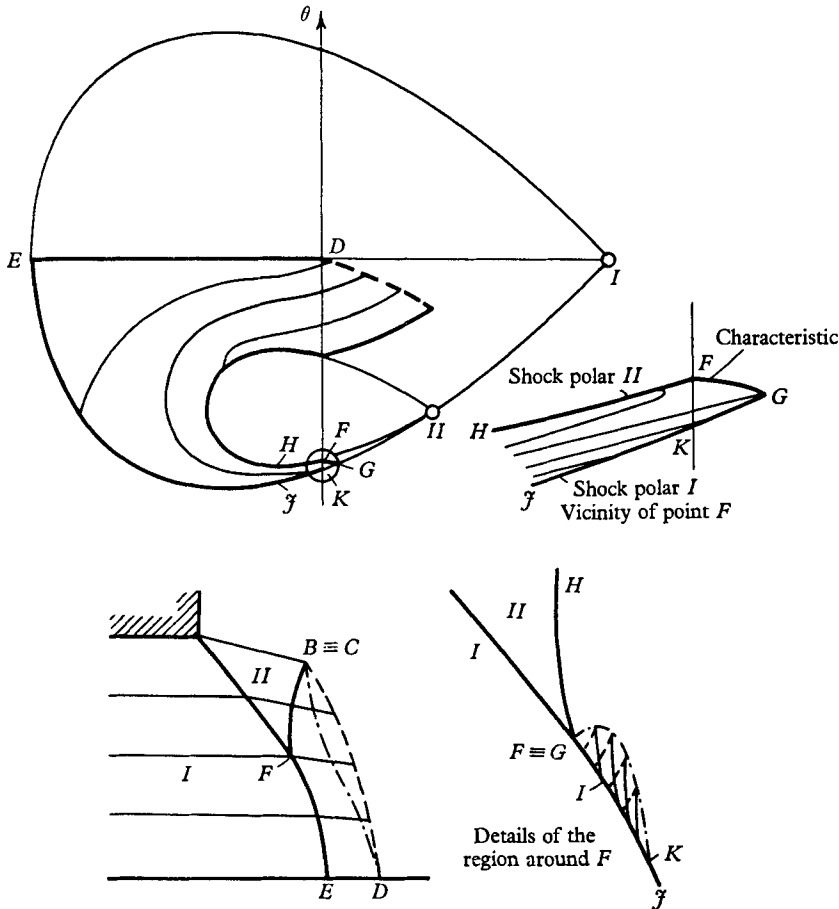

FIGURE 8. Guderley's solution for the flow at the triple point when the shock polars do not intersect. The characteristic FG represents a point-localized Prandtl-Meyer expansion at F . The flow in the vicinity of point F , with indications of the streamline pattern in the hodograph plane and of the limited supersonic region in the physical plane, is illustrated by two enlarged sketches of the neighbourhood of F (Guderley 1962).

Mach number. At last there is a small range where Guderley's solution is applicable. Sternberg (1959) has shown that the lower part of the hodograph plane in a Guderley intersection does not reveal itself in experiments and must therefore lie in the experimentally obscure region near the triple point, if it has any physical reality. Yet an analysis of shock-tube data and electric tank experiments carried out by Sternberg requires that this region should be clearly distinguishable. He admits that the experimental evidence is not conclusive, but says, quite rightly, that in any case shock polars ought not to be used for regions in which the radius of curvature of shocks is comparable with the thickness as

here. All of the streamlines on which the ratio of these quantities is unfavourable occur within 0.1 mm of the triple point and are therefore unobservable in the experiments. Nevertheless, as he points out, the distributions of pressure and temperature within the incident and reflected shocks, on classical Becker theory—which is good enough for this comparison—are incompatible with that through the Mach stem, and he concludes that there must be a finite shock zone with significant pressure and temperature gradients along the front as well as normal

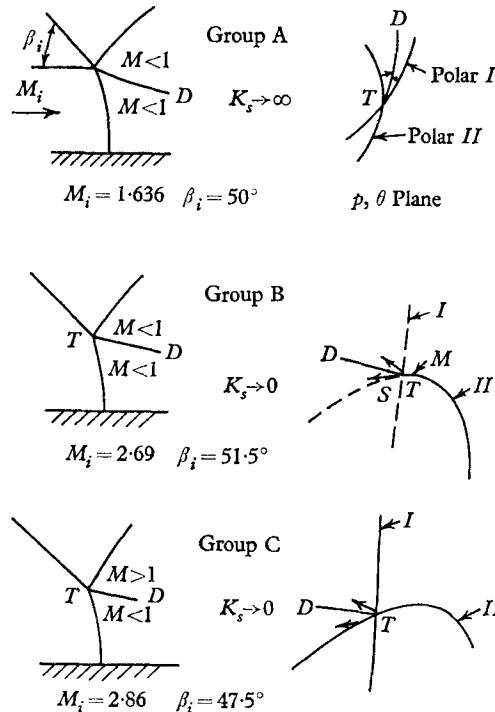

FIGURE 9. Types of three-shock intersections. Arrows in the right-hand sketches show the directions of streamlines on (p, θ) shock polars, illustrating their incompatibility in the hodograph plane (Sternberg 1959).

to it. He calls this region a non-Rankine–Hugoniot shock wave, and constructs a model for it based on Becker solutions for individual shocks and conservation over-all. For the case considered in detail in his paper he finds that the height of the transition region is several times greater than the shock thickness, that the reflected shock and Mach stem have large curvatures in a small unobservable region, and that equality of pressure and direction across the ‘slipstream’ will not necessarily apply immediately downstream; there will be an ‘equalization zone’, of size dependent upon the subsonic flow field downstream. On the other hand, the height of the non-Rankine–Hugoniot zone is usually very much less than the scale length in a wind-tunnel test or the distance from the apex of the wedge in a pseudo-stationary flow, and for this reason the pseudo-stationary conditions are observed for the path of the triple point. The non-Rankine–Hugoniot shock leads to a new boundary of the flow field in the hodograph plane linking the reflected and Mach shock polars. This boundary is not independent

of the subsonic downstream field; but experiments suggest that the particular shape of this boundary does not have much effect away from the intersection, and it is difficult to escape the conclusion that all Sternberg has *proved* is that the early pre-occupation with angle-measuring near the triple point was a waste of time in most cases. He has cast some doubt on the physical reality of Guderley's solutions, but he has certainly not proved that treatments of overall flow based on inviscid theory do not give good results, except in this non-Rankine-Hugoniot region. There is too much evidence, where direct comparisons have been made, that inviscid treatments of three-shock flows give good results, *even when no attempt is made to get the reflected shock correct*, as in the linearized approximations of Lighthill (1949*a*) and of Ting & Ludloff (1952) which assumed the reflected shock to be a Mach wave. Nevertheless, his work suggests another look at the nature of the flow between the shock-wave and the surface of a solid body in supersonic flow when this flow is subsonic and has a Mach number less than that corresponding to the Crocco point. Cabannes & Stael (1961) have worked out the details of the inviscid flow under these circumstances; the flow near the singular point is here additionally complicated by the presence of a boundary layer on the surface as well as infinite shock curvature!

3.5. General methods

At this point I might mention that Lighthill's (1949*a*) method of dealing with conical flows has led recently to a number of interesting investigations. There is Smyrl's solution (1963) for the impact of a shock wave of arbitrary strength on a supersonic aerofoil, built up from the conical solution appropriate to a wedge. For the latter (figure 10) there is an even more complicated shock wave pattern, of incident shock, initial attached shock, final attached shock, bridging shock, Mach stem and contact discontinuity *IO* dividing air which crosses the shock front directly from region *O* from that which crosses from region (2). Smyrl assumes that, outside the sonic circle, there are only uniform regions and that the shock front *IA* is straight, except for the portion *AB* which must bend in order to meet the wedge normally. This picture is the one giving the smallest and simplest disturbed region consistent with the physical facts. The hypotheses have been largely supported by an elegant use of the hydraulic analogy for an unsteady flow by Klein. A photograph taken from a film of Klein's work is shown in figure 11, plate 1.

Another recent application of these techniques has been to the problem of a shock-wave passing from land to water over an inclined bottom. The high ratio of the density of the water to air ensures only small displacements of the water surface. For a normal shock the reflexion is necessarily a Mach reflexion. The solution involves an additional wave in either the air or the water resulting from the difference in sound speeds across the interface. This work is due to Bezhanov (1962).

3.6. Computational solutions

I have yet to mention mathematical experimentation in this field. Ludloff & Friedman (1955) did two computations for the case in which the shock incident

on a wedge is not sufficient to provide an attached shock. The bow shock then stands off from the wedge and since the whole picture scales up with time, it must recede further and further away. Unless the wedge side is finite there is then no ultimate steady solution. The problem of relating the stand-off to wedge side by consideration of the asymptotic nature of the unsteady flow seems never to have been studied. The first of the methods used by Ludloff & Friedman in

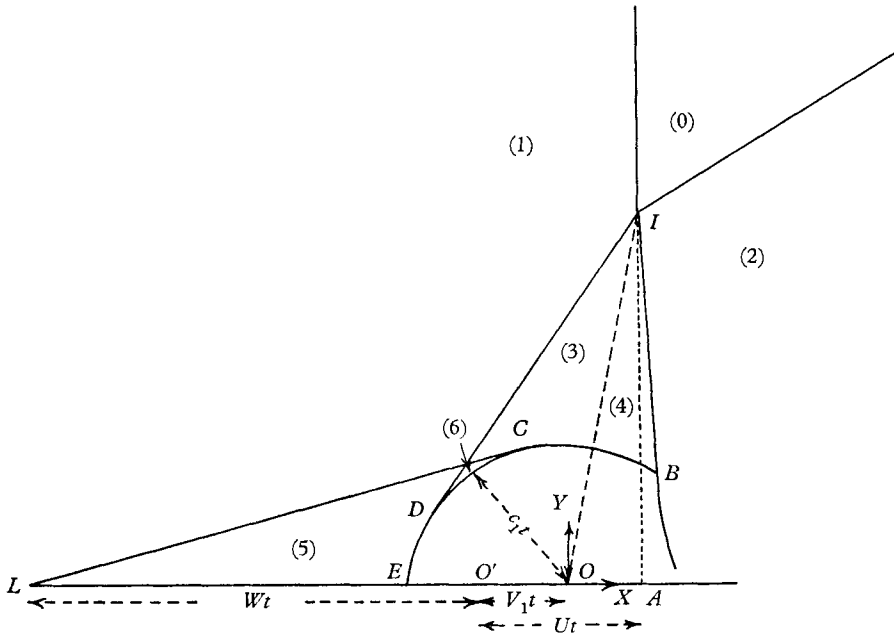

FIGURE 10. The main flow regions after the flying wedge has penetrated the shock front. L is the leading edge, I the intersection of the shock and the original bow-wave. ID is the bridging shock, LC the new bow-wave. U is the speed of the oncoming shock, V_1 the speed of the flow behind the shock and W the speed of the wedge. B, C, D, E all lie on the sonic circle with centre O and radius $c_1 t$. OX, OY are axes of co-ordinates (Smyrl 1963).

their work involves the solution of an elliptic problem with appropriate conditions imposed all round the boundary of the region of disturbed flow. The solution is found by trial-and-error procedure, using interferograms as a guide. It is shown, by an analytical argument, that the point at which the contact discontinuity from the triple point meets the wall is a point of concurrence of the lines of constant entropy and a point of minimum pressure along the wall, a feature confirmed by experiment. In the second approach the variables x, y, t are retained in order to ensure that the equations remain hyperbolic in character, and the pseudo-stationary flow is allowed to 'develop', starting with the condition that at time $t = 0$ a plane shock, treated as a step-function, hits the wedge. The initial condition together with the requirement of tangential flow along the wedge is sufficient to determine the whole flow at later times. When the partial differential equations are replaced by finite difference equations for the numerical procedure, the initial discontinuities are automatically removed. A continuous initial-value problem arises, the solution of which reveals the loca-

tion of shocks and slip-stream by means of relatively sudden steep changes of density. In this particular flow the density gradients appear to tend more and more with increasing time towards the pseudo-stationary form that must represent the limit as $t \rightarrow \infty$ and the method of starting up the flow becomes irrelevant. Entropy changes occur, at first sight a strange result when only the basic differential equations of an ideal, inviscid fluid are used. The density

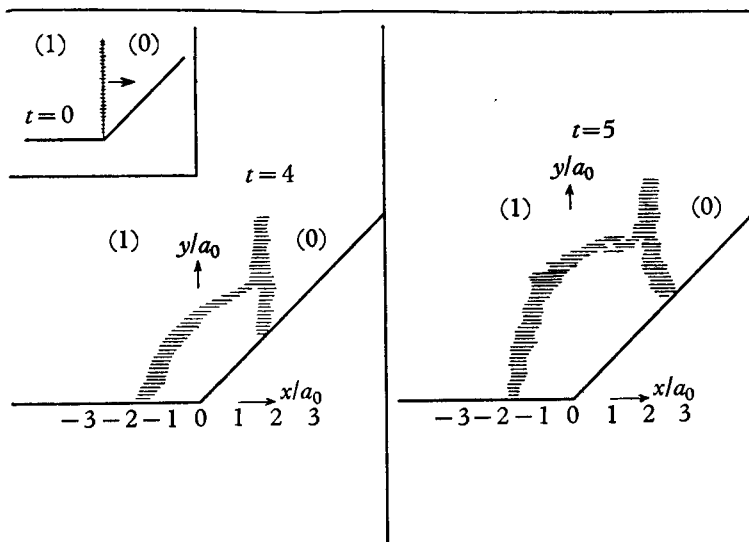

FIGURE 12. Numerical results showing the development of conical flow over a wedge after impact by a plane shock. The density gradients after cycles 0, 4 and 5 of the calculation are illustrated. The co-ordinates are x/a_0 , y/a_0 , where a_0 is the speed of sound ahead of the advancing shock (Ludloff & Friedman 1955).

gradients are indicated in figure 12. Already after the 4th cycle the split into reflected shock and Mach stem has occurred. These remarkable patterns stem from two features of the mathematics and physics, namely:

(i) The difference between the differential and difference forms of the equations of motion acts as a kind of artificial viscosity. This produces the necessary entropy changes.

(ii) The Rankine-Hugoniot equations, giving the correct conditions on opposite sides of a shock wave, do not depend in any way on the viscosity coefficients; thus the artificial 'viscosity' has only a catalytic role to play, for which it serves as well as the true viscosity.

The idea of using an artificial viscosity, due to von Neumann, has been exploited in a number of computations involving the propagation of blast waves. It has sometimes been deliberately programmed in a special form so as to be introduced whenever a compressive phase occurs. This technique has still an important part to play in the theoretical investigation of shock phenomena. I believe it has not been pursued more strongly because the early work did reveal difficulties as to the stability of the numerical solution. I understand that Richtmyer and his associates have recently taken up research again into the problem of the representation of shocks on computers. In the Royal College of

Science and Technology, Glasgow, J. G. Fraser has been working on such representation with a view to a computational check on Smyrl's work, and Warner (1962) has investigated the effect of shock impact on an explosive, determining relations governing the initiation of detonation under the effect of reaction in the explosive.

4. Shock diffraction

The solution of the problem of diffraction of waves of finite amplitude has not made as much progress as might have been hoped. The earliest work was done by Bargmann (1945), who, in an American report of limited circulation, used the pseudo-stationary property to develop a first-order solution for a weak shock reflected at a concave corner of small angle. This work assumed irrotational flow behind the shocks. It was followed up theoretically by Lighthill (1949*a*, 1950) who took into account the vorticity behind the curved shock waves. Lighthill's method, free of the restriction to weak shocks, was nevertheless applicable only to conical flows. A more general approximate method was developed by Ting & Ludloff (1952). An excellent summary of work involving approximate methods up to 1952 is contained in an article by Ludloff (1953), and there is some comparison between theory and experiment in the work of Fletcher, Taub & Bleakney (1951). Experimental data have been recorded by Bleakney, White & Griffiths (1950).

The exact equations of pseudo-stationary flow have not as far as I know received a great deal of attention. Jones, Martin & Thornhill (1951) showed that when a strong shock followed by supersonic flow is deflected by a finite convex corner there is a limited region of Prandtl-Meyer flow near the corner expanding uniformly with time. This Prandtl-Meyer flow is a solution of the equations expressed in pseudo-stationary co-ordinates but its curved set of characteristics is completely different from the corresponding set in stationary flow. At the International Congress of Mathematicians in Amsterdam, Thornhill (1954) spoke about the corresponding problem of a shock with subsonic flow behind it relative to still air ahead. He discussed the behaviour of the subsonic pseudo-stationary streamline along the wall which has to separate at the corner. This streamline turns round to run tangentially into the inclined wall in a direction towards the corner and Thornhill conjectured that all other pseudo-stationary streamlines concur at the point where this happens. It is known from experiment that a vortex forms downstream of the corner in this situation. Furthermore, this vortex appears to grow in a pseudo-stationary manner. Work on the full equations seems to have expired at this stage, and I have nothing more to report on it!

Further examples of shock diffraction will be touched upon in the next section.

5. Approximate solutions

Between the analytical solutions of shock-wave problems, which are very few in number, and the numerical solution of shock-wave problems, which is a modern cult and naturally one of growing importance, comes the *art* of approximate

solution. I use the word *art* very deliberately! Approximate solutions can be of tremendous importance if they yield even qualitative understanding of the dominating influences in a given physical situation; if they are capable of giving solutions that are quantitatively of sufficient accuracy, so much the better—they save a lot of complicated numerical work.

A great deal has been written during the past 10 years on the subject. The most extensive progress started with the paper by Lighthill (1949*b*) on rendering approximate solutions of the equations of motion uniformly valid near to the singular lines, e.g. on characteristics. Whitham, who is acknowledged in Lighthill's paper as having helped in the discovery of the method, but who seems to me to have been given insufficient credit by later writers, extended the theory (1950, 1952) to improve, for example, the understanding of the *N*-wave formed by a spherical shock wave following another such shock wave, as in a blast wave. The general idea is to find a means of taking into account the distortion of characteristics; the solution given by linearized theory is taken as a correct first approximation everywhere; a new variable τ is introduced, which would be constant on the linear characteristic, and this has to be determined to make each wavelet $\tau = \text{const.}$ travel with the correct speed, allowing for the non-linear convective effects. These methods have been adapted to both unsteady and steady problems involving two variables. In 1956 Whitham came forward with an extension of this theory to problems lacking directional symmetry. It is based on the fact that, according to the theory of sound, a wave front carrying a disturbance from a surface *S* of arbitrary shape moves along the normals to *S* with the local speed of sound. Normals are orthogonal trajectories of successive positions of the wave front and are known as 'rays'; they may be thought of as carrying the disturbance. The solution of this problem in the theory of sound gives the magnitude of the disturbance and the variation in the magnitude of the pressure jump at the wave front as it moves out along a ray. Near the head of the wave the amplitude can be deduced from the approximation of 'geometrical acoustics' without knowledge of the full solution, for in certain circumstances the energy propagated down a narrow ray tube formed by a bundle of neighbouring rays is conserved; we may neglect reflexion and diffraction of energy. Thus, since the flux of energy is proportional to $a^2 A(s)$, where a is the amplitude of the wave and $A(s)$ the cross-sectional area of the ray tube at a distance s along the ray, $a \propto A^{-\frac{1}{2}}$. When a shock wave replaces the wave front we have to allow for the dissipation of energy, but nevertheless we may often assume that, for them also, the propagation down each *ray tube* may be treated separately. This gives a two-variable problem depending on time t and distance s . The effect is that if the strength varies along a shock, there will be a tendency for the shock to refract away from the position predicted by linear theory; thus the true orthogonal trajectories curve away from the straight rays; nevertheless, the displacement is small compared with s unless the strength varies rapidly along the shock, and may usually be neglected. Whitham applied this theory for weak waves to the *N*-waves such as occur in blast problems, unsymmetrical explosions, steady supersonic cone theory, thin wings of finite span and supersonic bangs. The restriction to propagation through a uniform medium is not essential.

If the sound speed is not constant, the rays curve as the wave front is refracted. The method might perhaps be used for the further generalization of non-uniform motion ahead of the shock, and I believe that the Royal Aircraft Establishment is looking at this at the present time with a view to understanding the refraction of a sonic bang moving through a shear layer in the upper atmosphere.

These ideas led Whitham (1957, 1959) on to the construction of an approximate method for strong shocks depending on using the position of shocks at successive instants of time and their orthogonal trajectories, which he calls ‘rays’, as a basis for orthogonal co-ordinates in two dimensions. He coupled with this system the idea of channelling the energy between the rays. When he tried to extend this notion to 3 dimensions he met the difficulties implied by Darboux’s theorem which states that a given set of surfaces cannot in general be one family of a set of orthogonal co-ordinates. He therefore started again from first principles (figure 13), describing the shock by $a_0 t = \alpha(x, y, z)$, where a_0 is the (constant)

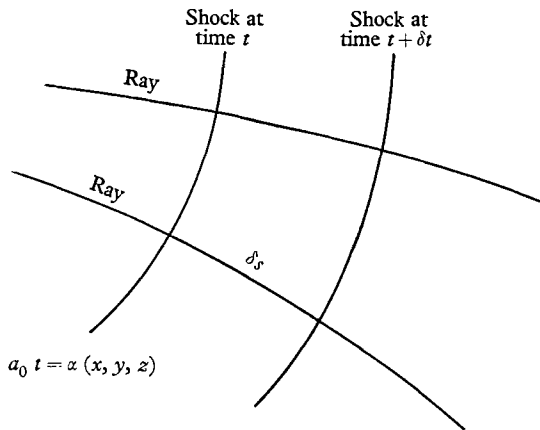

FIGURE 13. Whitham’s basis of shock waves and rays for the approximate treatment of three-dimensional problems on the propagation of shocks.

speed of sound ahead of the shock, and letting δs be distance along a ray between the shock positions at times $t, t + \delta t$. Then since $a_0 \delta t = \delta s |\nabla \alpha|$, the Mach shock number M is given by $M = 1/|\nabla \alpha|$. Let $\mathbf{i}(x, y, z)$ be the unit vector in the ray direction, being normal to $a_0 t = \alpha$. Then

$$\mathbf{i} = \frac{\nabla \alpha}{|\nabla \alpha|} = M \nabla \alpha. \tag{1}$$

By considering a small length of a narrow ray tube with end sections parts of surfaces $\alpha = \text{const.}$ and letting A be proportional to the cross-sectional area of the tube, one may obtain the kinematical relation derived from the flux of \mathbf{i}/A ,

$$\nabla \cdot (A^{-1} M \nabla \alpha) = 0. \tag{2}$$

To solve any problem we must supplement this kinematical relationship with a dynamical one. Whitham chose to use the relation $A = A(M)$ found by Chisnell (1957) by integration of Chester’s well-known formula for the change in Mach number due to a small change in channel area. Immediately behind the shock

the particles are moving in the direction of the rays, and the assumption is, once again, that later divergence of rays and particle paths is unimportant.

In two dimensions (2) reduces to $\partial\theta/\partial\beta = M^{-1}\partial A/\partial\alpha$, if $\beta = \text{const.}$ denotes rays and θ is the inclination of a ray to a fixed axis, say the x -axis. From (1) we may derive easily that $\partial\theta/\partial\alpha = -A^{-1}\partial M/\partial\beta$. Both of these relations may be seen at once from a sketch of an elementary area in the (α, β) -plane. We are able to build up a theory of characteristics for these hyperbolic equations, for

$$\theta \pm \int \frac{dM}{Ac} = \text{const.} \quad \text{on} \quad \frac{d\beta}{d\alpha} = \pm c, \quad \text{where} \quad c = \left(\frac{-d(M^2)}{d(A^2)} \right)^{\frac{1}{2}},$$

a result analogous to that for the invariants of two-dimensional steady flow or the Riemann invariants of one-dimensional unsteady flow.

We have kinematical waves travelling in each direction on the shock face, and we may expect the theory to be usefully applied in diffraction problems because in these, as we have seen, the detailed flow behind the shock does not seem to affect the overall pattern in an essential way. The propagation

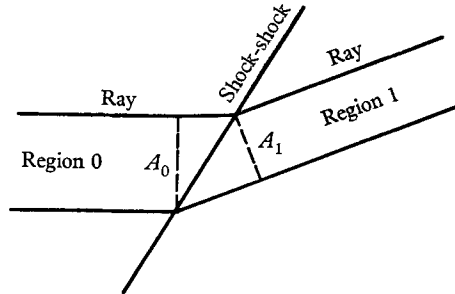

FIGURE 14. Illustration of the passage of a ray tube across a shock-shock in three dimensions.

speed $d\beta/d\alpha$ is an increasing function of M ; thus, by analogy, we may expect a wave with increasing M to *break*. Then it will be necessary to fit in a discontinuity in Mach number travelling along the shock. Whitham calls this a *shock-shock*. It has to be interpreted as the trace of a cylindrical wave spreading out in the flow behind the shock. In a diffraction problem it thus represents the motion of the triple point. He uses the two-dimensional theory (1957) to discuss diffraction by a wall, including the interesting variation of reflexion from a *nearly plane* wall, and the three-dimensional theory (1959) to treat of diffraction by a cone. The relations holding across a shock-shock in three dimensions (figure 14) are obtained by requiring (i) α to be continuous across it, or tangential derivatives equal on the two sides (0, 1); (ii) the projections of the ray tubes A_0, A_1 on the shock-shock to be equal; this is equivalent to the statement that the flux of $A^{-1}M \cdot \nabla\alpha$ is preserved across the discontinuity. It is interesting that the two equations obtained are analogous to continuity of tangential component of velocity and conservation of mass across an oblique shock, with $\nabla\alpha$ corresponding to the velocity and M/A to the density ρ . To complete the analogy we should need a relation involving normal component of momentum and allowing for entropy changes. This would be equivalent to taking a different functional

dependence of A on M in the two regions. This is not done, so we effectively assume potential flow behind a shock wave.

This interesting paper led Bryson & Gross (1961) to carry out theoretical and experimental work on diffraction by cones, a cylinder and a sphere. For cones with shock Mach number 3.68 the shock-shock angle was measured and figure 15 shows the agreement between observation and Whitham's theory. The experimental points tend to fall below the theoretical. While the theory gives Mach

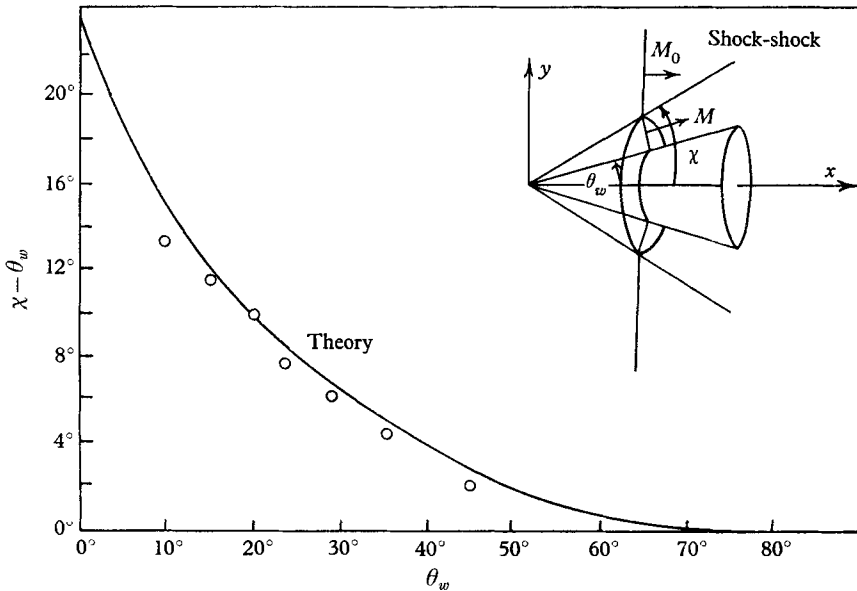

FIGURE 15. Shock-shock angle χ vs cone semi-apex angle θ_w for shock Mach number $M_0 = 3.68$; \circ Experimental points (Bryson & Gross 1961).

reflexion for all θ_w (the semi-angle of the cone) one can see that χ is practically equal to θ_w for $\theta_w > 70^\circ$. Incidentally, I know of no analysis of the possibility of regular reflexion on a cone, although it has been claimed (see Courant & Friedrichs 1948) that reflexion with conical flow is not possible at an axis of symmetry. The shape of the Mach shock can be found from Whitham's theory and is found to be practically straight except for very small θ_w . The most extensive results were found for a $\frac{1}{2}$ in. diameter cylinder with Mach number 2.84, but with two different pressures behind the undisturbed shock corresponding to a factor 10 in the Reynolds number $(8, 0.8) \times 10^4$ based on the speed behind the incident shock. The diffraction pattern (figure 16, plate 2) was followed over a distance of travel of the incident shock of about 7 diameters. It is significant that the change in Reynolds number had no distinguishable effect on the loci of triple points. I use the plural because here we have first a regular reflexion at the front of the cylinder, Mach reflexion beginning between the radii corresponding to 40° and 50° ; the reflexion of the Mach stems at the rear is itself regular at first, and then produces a second Mach reflexion beginning at rather less than one diameter behind the cylinder. (Diffraction on a sphere follows the same qualitative pattern).

When the first Mach reflexion begins the boundary-layer interaction causes the slip surface to curl up into a vortex. If one assumes that this vortex retains much the same circulation throughout its life, it should follow a particle path. Whitham identifies the rays, the orthogonal trajectories of the shocks, with particle paths, and figure 17 shows that the path of the vortex follows a ray closely until it approaches the plane of a symmetry at the rear of the cylinder.

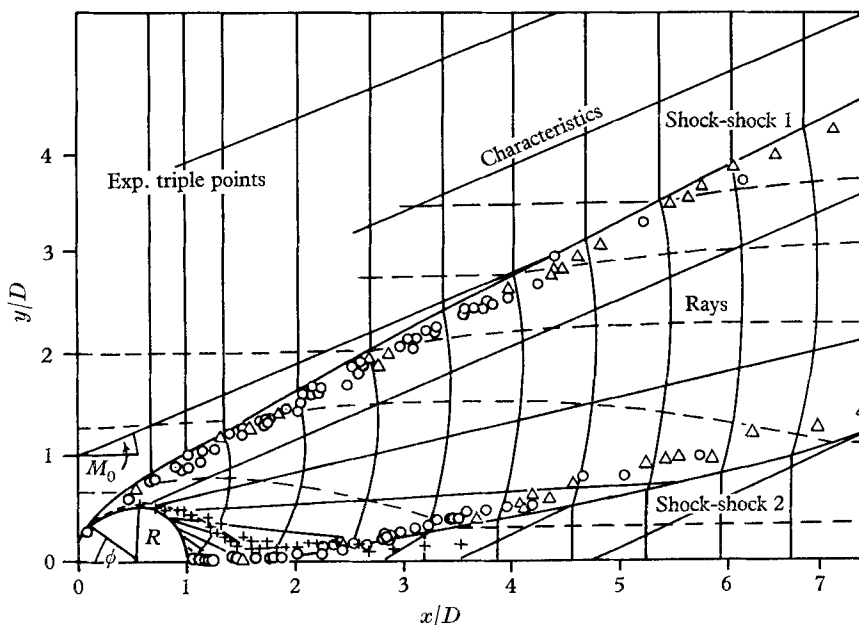

FIGURE 17. Diffraction on a cylinder; $M_0 = 2.81$. \circ $Re = 7.79 \times 10^4$,
 \triangle $Re = 0.78 \times 10^4$, + vortex locus (Bryson & Gross 1961).

Whitham's theory predicted that the diffraction patterns would be the same for all incident Mach numbers $M_0 \geq 3$. The experimental loci of triple points coincided for $M_0 = 2.85$ and $M_0 = 4.41$ with the shock-shock predicted for $M_0 \gg 1$.

By approximating to the Mach shock by straight lines near the nose Bryson & Gross calculated the shock-shock position at 45° from the nose and then found it possible to continue right round and behind the cylinder, by means of the theory of characteristics for Whitham's equations, to account for the second shock-shock. For the sphere the calculation could not be extended so far, because the characteristics proved to be highly divergent.

The method could be used for other, quite complicated axially symmetrical flows and for other problems where there is similarity of some kind. Whitham mentions, for example, diffraction on a flat-plate delta wing at incidence. Here $\alpha = xf(y/x, z/x)$, corresponding to cone field theory in supersonic flow. For genuine 3-variable problems the theory leads to partial differential equations quite similar to those occurring in the *exact* formulation of two-dimensional time-dependent gas dynamics, and numerical methods for this kind of equations have already been devised.

6. Boundary-layer effects

In all this we have been concerned in the main with the inviscid pattern without consideration of the effect of boundary layers. The properties of the oblique reflexion of a shock wave from the boundary layer on a body have been well understood for a decade. Lighthill (1953) explained upstream influence in a general way and it was shown that the role of viscosity was more important than was implied by the suggestion that it just provided a subsonic region

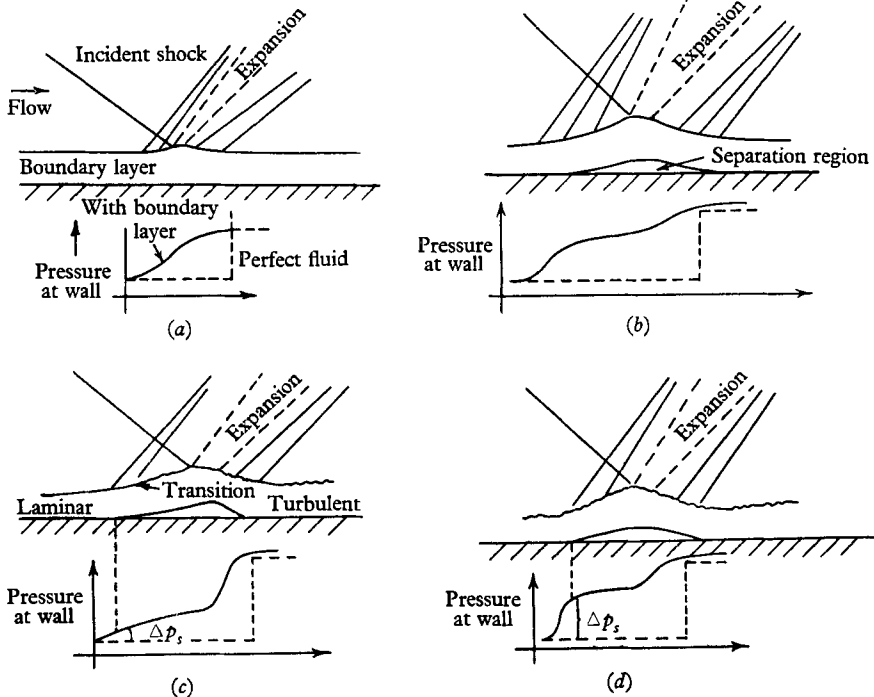

FIGURE 18. (a) Interaction with no flow separation; (b) interaction on laminar boundary layer with separation; (c) interaction on laminar boundary layer causing transition to turbulent flow within the separated layer; (d) interaction on turbulent boundary layer with separation (Pain & Rogers 1962).

through which disturbances could propagate. One has to consider the interaction between the boundary-layer thickness and the pressure change it produces in the general stream. The positive pressure gradient provided by a shock causes a thickening of the boundary layer. The compression of streamlines *increases* the pressure gradient in a *supersonic* stream. This causes further thickening and so on. Since the laminar boundary thickens much more easily than a turbulent one the effect is much more marked in a laminar one. The possibilities are shown in a schematic way in figure 18.

I do not wish to dwell any longer on this kind of interaction. There is a good, brief account in the article by Pain & Rogers (1962). Rather I wish to turn to the problem of boundary-layer effects on shock waves moving along or normal to a wall. The problem is quite different from the one just mentioned, because

now, relative to the shock wave, the wall is in motion with supersonic speed. Indeed, the viscous effect is almost entirely downstream of the shock wave. The problem which has created the most interest concerns the propagation of the shock wave down a shock tube. The head-on reflexion from the rear-end is very complicated, because the reflected shock has to move through a flow with a growing boundary layer on the wall ahead of it. The inviscid core is not uniform in the direction of motion, even when one neglects relaxation effects and disturbances from the breaking of the membrane. Rudinger (1961) made an attempt on this problem, allowing for this non-uniformity and using the properties of characteristics behind the reflected shock under the approximations that the fluid is at rest and the reflected shock speed constant. This work has recently been improved by Woods (1962) who has used perturbation methods similar to Goldsworthy's to allow for the small motion behind the reflected shock. On the assumption of no separation of the boundary layer from the wall on passage through the shock he finds that, while the effect of the boundary layer itself is to reduce the pressure at the tube end as time goes on, the result of the non-uniformities of the flow ahead of the reflected shock is to raise it by a larger amount. While the analysis is improved in this paper, it is not clear that it gives even as good agreement with experiment as Rudinger's work. However, on the positive side, Woods has created a model of a separating boundary layer at the wall including a 'bubble' of boundary-layer air at the junction of shock wave and boundary layer; this 'bubble' arises when the stagnation pressure in the wall boundary layer is lower than the reflected shock pressure, causing separation of the layer. The 'bubble' grows with time, moves with the shock wave, and mass and vorticity are continually fed into it. Woods has found an initial pressure drop at the tube end under these circumstances, as predicted by Mark (1958), and as observed by Holder & Schultz (1960).

The incident wave in the shock tube, moving *normal* to the wall, produces the wall layer, and this in turn produces waves which tend to slow down the shock. There are several treatments of the boundary-layer flow. A general account has recently been given by Becker (1961). For a shock-wave or a simple wave moving along a wall (along the x -axis) with a *laminar, unseparated boundary layer* he uses axes fixed in the wall, takes $\xi = 1 - x(u_0 t)$, where t is the time and u_0 a reference velocity, and replaces the normal co-ordinate z by $z' = \int_0^z (\rho/\rho_0) dz$; he introduces $\zeta = z'/(v_0 t)^{\frac{1}{2}}$ and a stream function $\psi = u_0(v_0 t)^{\frac{1}{2}} f(\xi, \zeta)$ with temperature $T = T_0 \vartheta(\xi, \zeta)$, T_0 and v_0 being a reference temperature and viscosity coefficient, respectively. He obtains similarity solutions in terms of the parameter $\sigma = \zeta \xi^{-\frac{1}{2}}$, equivalent to $z' x^{-\frac{1}{2}}$ for axes fixed relative to the shock. For $\gamma = 1.4$ the boundary-layer thickness (99%) parameter $\delta/(v_e t)^{\frac{1}{2}}$, where v_e is the kinematic viscosity coefficient in the external stream, varies between 3.6 for weak shocks and 6.9 for very strong ones. He goes on to discuss turbulent layers, which of necessity have to be approached in a rather empirical manner.

Mirels & Hamman (1962) have extended these ideas to two-dimensional and axially-symmetrical laminar boundary layers behind plane, cylindrical and spherical shocks moving according to the power law $x \propto t^m$. Typical cases arise

behind shocks from exploding wires in or normal to a plane, and the shock wave from an atomic explosion.

It is not my intention to discuss the theoretical treatment of shock tube flows in particular—Bradley's book does this in considerable detail—but to look at it from the aspect of shock reflexion. The solution for laminar flow has a singular point at the foot of the shock. The shock is always normal to the wall in this solution, while to be physically correct the shock must be curved at the wall, on account of the action of the boundary layer. This follows whether the boundary layer is looked upon as a thin obstacle past which the outer flow is deflected, or whether the simpler fact is taken into account that the stream has no change of direction or speed relative to the shock at the wall. Shock-tube experiments seem to indicate that the effect is not readily observable or significant at ordinary densities. But in experiments at low density, the curvature is marked and the interaction certainly not negligible. An attempt to allow for shock curvature was made first by Hartunian (1961), who took for the *assumed small* vertical perturbation velocity behind the shock on a flat plate the function

$$v(x, 0) = Bx^{-\frac{1}{2}},$$

treating the boundary layer as a slender body. He supposed the shock wave to be perturbed by a small angle ϵ and, assuming a weak shock, neglected the vorticity downstream. With $u(0, y) = 0$, for the horizontal perturbation velocity u , with $u, v \rightarrow 0$ as $y \rightarrow \infty$, he solved the linearized equation

$$\beta^2 \psi_{xx} + \psi_{yy} = 0, \quad \text{where} \quad \psi_y = \beta^2 u, \quad \psi_x = -v \quad \text{and} \quad \beta^2 = 1 - M_\epsilon^2$$

and found a shock wave of finite curvature but tangential to the plate at its foot. It is clear, after reading this paper, that some account must be taken of shock structure if this problem is to be solved in a physically acceptable manner, and an attempt has been made by Sichel (1962). For a weak shock there is little difference between free stream and wall speed, and so the boundary layer equations may be linearized. Mirels (1955) proved that this gives an excellent approximation to exact solutions for weak shocks. Sichel subdivides the leading edge flow into a shear layer near the wall dominated by the transverse shear stress and a free stream or shock region where the longitudinal viscous stress is most important. He expands in powers of a small parameter ϵ denoting the departure of the Mach number from unity and he stretches the co-ordinate system x with respect to shock thickness λ , and y with respect to shear-layer thickness δ . The shock thickness, following Lighthill (1956), is given by $\lambda = \nu^*/a^*\epsilon$, where $*$ denotes the sonic condition, ν the kinematic viscosity and a the speed of sound, while δ is not known *a priori*. He does an order-of-magnitude analysis to show that $\delta/\lambda = O(\epsilon^{\frac{1}{2}})$ for weak shocks and that $v = O(\epsilon^{\frac{1}{2}})$. His equations reduce to Mirels's linearized boundary-layer equations with variable free-stream pressure. The boundary-layer approximation can be extended right to the *base of the shock wave* if the latter is weak. The equation for the first-order perturbation $u^{(1)}$ to the x -component, u , of the velocity is of heat-conduction type, and can be readily solved with external flow $u^{(1)}(x, \infty)$ corresponding to Taylor's weak shock structure. The downstream flow turns out to be asymptotic

to Mirels' solution, as one might expect (figure 19). Unfortunately $v(x, \infty) = O(\epsilon^{\frac{1}{2}})$ which is appropriate to an oblique transonic shock, but the free stream flow cannot be represented exactly by such a shock because there is no reason why it should produce the required variation of $v^{(1)}(x, \infty)$ generated by the shear layer. Sichel concludes, as Sternberg did, that the shock structure must be two-dimensional near the outer edge of the shear layer. He then describes the non-

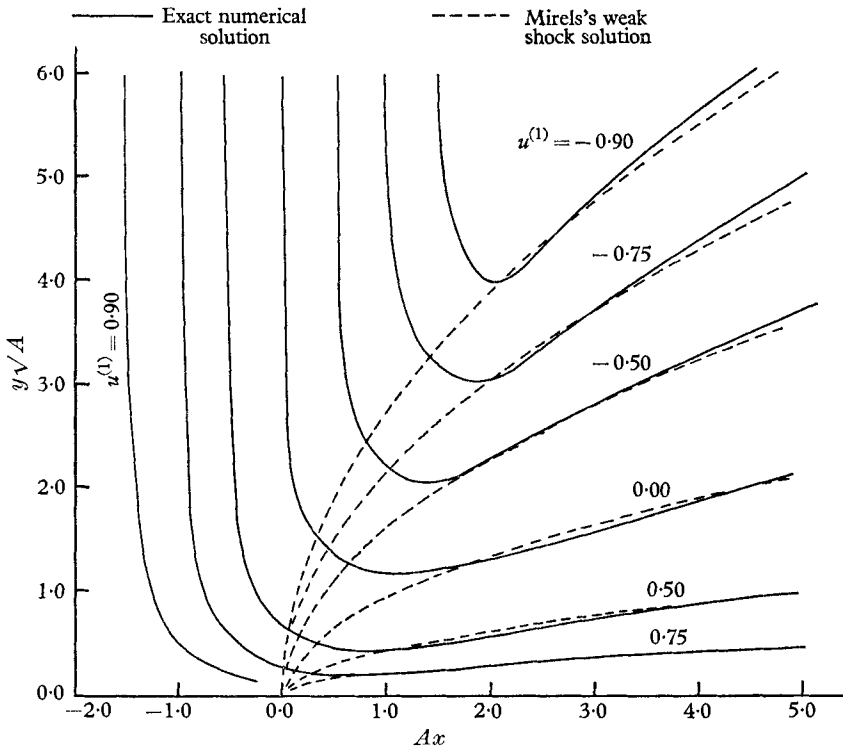

FIGURE 19. Lines of constant velocity within the shear layer. Velocities are made non-dimensional with respect to the critical speed. The parameter A occurs in the Taylor solution for the structure of a weak one-dimensional shock, for which, with $u = 1 + \epsilon u^{(1)}$, $u^{(1)} = -\tanh Ax$ (Sichel 1962).

Hugoniot shock region by appropriate Navier-Stokes equations in terms of x and $\hat{y} = ya^*\epsilon^{\frac{1}{2}}/v^*$. On the basis of a dimensional analysis he shows that, for the weak shock, the flow will be irrotational and that, with $u = \phi_x$, $v = \phi_y$, the Navier-Stokes equations for an ideal gas lead to the potential equation

$$\{1 + (\gamma - 1)/Pr\} \phi_{xxx} - (\gamma + 1) \phi_x \phi_{xx} + \phi_{yy} = 0,$$

where Pr is the Prandtl number. The details of the derivation for a general gas are given in a report by Sichel (1961)†. He has called this equation the *viscous-transonic equation*. The first term represents the dissipative effects of heat conduction and longitudinal viscous stress, the second is convective in origin and the third term is required by the conservation of mass, coming in because the viscous flow under consideration is two-dimensional. The equation reduces

† I am indebted to Dr A. B. Tayler for this reference.

to the transonic equation when the first term drops out, and to Burgers' equation for one-dimensional steady flow when the last term disappears. Unable to solve his equation with the correct $v^{(1)}$ Sichel makes do with the well-known Taylor shock structure with a uniform velocity parallel to the shock to obtain $u^{(1)}$ and $v^{(1)}$ for an oblique transonic shock inclined at an angle σ to the vertical where $\sigma = \alpha \epsilon^{\frac{1}{2}}$ and α is called the obliquity parameter. This is actually a solution of the viscous-transonic equation. He chooses α by making the maximum vertical velocities downstream of the shock and in the outer edge of the shear layer equal, and shows that for this particular value there is quite good matching of the $v^{(1)}$ profiles near the base of the shock. He now seeks to find the inviscid flow between the shock and shear layer, and he does this by solving Laplace's equation for this region, by an iterative method. His method, in the end, turns towards Hartunian's but he has removed the singularity in the velocities and obtained a finite angle of the shock at the wall. It is interesting to note, however, that his results are asymptotic to Hartunian's and, indeed, indistinguishable from the latter at four or five shock thicknesses away from the leading edge. Also, an interesting consequence of the difficulties of the analysis is the infinite curvature that even Sichel is left with, at the last, at the foot of the shock. It is significant that Hugoniot conditions are no longer satisfied in the interaction zone, where the horizontal velocity overshoots its Hugoniot value, representing the sucking of fluid into the boundary layer.

7. Conclusion

I have said enough, I think, to show the close relation between all these reflexion problems. The outcome seems to me to be that the methods of the applied mathematician are vindicated, very largely, unless one really wants to know the intimate details of the reactions near the triple point or the base of a shock! The progress is quite clear. Sichel has pointed out that his methods could be applied to Mach reflexions. I think it would be interesting to use methods like Hartunian's to deal with the reflexion of an oblique shock, or like Sichel's using two Taylor waves in tandem for the external flow. Could one not find the solution by numerical methods, assuming such an external flow, for the *Navier-Stokes* equations in two dimensions? The problem is of interest from the point of view of blast and also, particularly for weak waves, in the effect, on reaching the ground, of air shocks from aircraft. This problem has engaged the attention of the Royal Aircraft Establishment where it was found that while records taken at some feet above the ground show very sharp incident and reflected shocks, the records taken at ground level show shocks a foot thick or thereabouts. Calculations of the kind I have indicated might throw light on these results.

It will be noticed how little has been said about anything other than two-dimensional flows. There is need to study the reflexion of spherical shocks from one another and from the ground, in connexion with true blast studies, and related to this is the reflexion of shocks moving through non-homogeneous layers like the earth's atmosphere. Lastly, the extension of many of these solutions to flows involving other than very weak shocks, while probably requiring numerical techniques, would be of considerable importance.

REFERENCES

- ABLOW, C. M. 1960 *Quart. Appl. Math.* **18**, 15.
- BARGMANN, V. 1945 *O.S.R.D. Rep.* no. 5171.
- BECKER, E. 1961 *Rep. Aero. Sci.* **1**, 104.
- BEZHANOV, K. A. 1962 *U.S.S.R. Computing Math. Math. Phys.* **1**, 142.
- BLEAKNEY, W. & TAUB, A. H. 1949 *Rev. Mod. Phys.* **21**, 584.
- BLEAKNEY, W., WHITE, D. R. & GRIFFITHS, W. C. 1950 *J. Appl. Mech.* **17**, 439.
- BRADLEY, J. N. 1962 *Shock Waves in Chemistry and Physics*. London: Methuen.
- BRYSON, A. E. & GROSS, R. W. F. 1961 *J. Fluid Mech.* **10**, 1.
- CABANNES, H. & STAEL, C. 1961 *J. Fluid Mech.* **10**, 289.
- CHISNELL, R. F. 1957 *J. Fluid Mech.* **2**, 286.
- CLUTTERHAM, D. R. & TAUB, A. H. 1956 *Proc. 6th Symp. in Appl. Math.*, p. 45. American Mathematical Society, New York.
- COURANT, R. & FRIEDRICHS, K. O. 1948 *Supersonic Flow and Shock Waves*. New York: Interscience.
- FLETCHER, C. H., TAUB, A. H. & BLEAKNEY, W. 1951 *Rev. Mod. Phys.* **23**, 271.
- GOLDSWORTHY, F. A. 1959 *J. Fluid Mech.* **5**, 164.
- GUDERLEY, K. G. 1962 *Theory of Transonic Flow*. Oxford: Pergamon Press.
- HARTUNIAN, R. A. 1961 *Phys. Fluids*, **4**, 1059.
- HOLDER, D. W. & SCHULTZ, D. L. 1960 *A.R.C. Current Paper*, no. 22152.
- JAHN, R. G. 1956 *J. Fluid Mech.* **1**, 457.
- JAHN, R. G. 1957 *J. Fluid Mech.* **2**, 33.
- JONES, D. M., MARTIN, P. M. E. & THORNHILL, C. K. 1951 *Proc. Roy. Soc. A*, **209**, 238.
- LEAN, G. H. 1943 *Rep. Aero. Res. Council*, no. 7495.
- LEAN, G. H. 1946 *Rep. Aero. Res. Council*, no. 10629.
- LIGHTHILL, M. J. 1949*a* *Proc. Roy. Soc. A*, **198**, 454.
- LIGHTHILL, M. J. 1949*b* *Phil. Mag.* (7) **11**, 1179.
- LIGHTHILL, M. J. 1950 *Proc. Roy. Soc. A*, **200**, 554.
- LIGHTHILL, M. J. 1953 *Proc. Roy. Soc. A*, **217**, 344.
- LIGHTHILL, M. J. 1956 Viscosity effects in sound waves of finite amplitude. *Surveys in Mechanics, G. I. Taylor 70th Anniversary Volume*, ed. G. K. Batchelor and R. M. Davies. Cambridge University Press.
- LUDLOFF, H. F. 1953 On aerodynamics of blasts. *Adv. Appl. Mech.* **3**. New York: Academic Press.
- LUDLOFF, H. F. & FRIEDMAN, M. B. 1955 *J. Aero. Sci.* **22**, 27.
- MARK, H. 1958 *NACA Tech. Mem.* no. 1418.
- MIRELS, H. 1955 *NACA Tech. Note*, no. 3401.
- MIRELS, H. & HAMMAN, J. 1962 *Phys. Fluids*, **5**, 91.
- PACK, D. C. 1957*a* *Phil. Mag.* (8), **2**, 182.
- PACK, D. C. 1957*b* *Phil. Mag.* (8), **2**, 189.
- PAIN, H. J. & ROGERS, E. W. E. 1962 *Rep. Prog. Phys.* **25**, 287.
- PATERSON, S. 1948 *Proc. Phys. Soc.* **61**, 119.
- POLACHEK, H. & SEEGER, R. J. 1949 *Proc. 1st Symp. Appl. Math.*, p. 119. American Mathematical Society, New York.
- POLACHEK, H. & SEEGER, R. J. 1951 *Phys. Rev.* **84**, 922.
- RUDINGER, G. 1961 *Phys. Fluids*, **4**, 1463.
- SICHEL, M. 1961 A study of the leading edge of a shock induced boundary layer. *Princeton University, Dep. Aero. Engng, Rep.* no. 540.
- SICHEL, M. 1962 *Phys. Fluids*, **5**, 1168.
- SMITH, L. G. 1945 *O.S.R.D. Report*, no. 6271.

- SMITH, W. R. 1959 *Phys. Fluids*, **2**, 533.
SMITH, W. R. 1962 *Phys. Fluids*, **5**, 593.
SMYRL, J. L. 1963 *J. Fluid Mech.* **15**, 223.
STERNBERG, J. 1959 *Phys. Fluids*, **2**, 179.
STREHLOW, R. A. & COHEN, A. 1962 *Phys. Fluids*, **5**, 97.
TAUB, A. H. 1947 *Phys. Rev.* **72**, 51.
THORNHILL, C. K. 1954 *Proc. Int. Congress of Mathematicians, Amsterdam*, **2**, 384.
TING, L. & LUDLOFF, H. F. 1952 *J. Aero. Sci.* **19**, 317.
WARNER, F. J. 1962 *Proc. 9th Int. Symp. on Combustion*. Cornell University, U.S.A.
WHITHAM, G. B. 1950 *Proc. Roy. Soc. A*, **203**, 571.
WHITHAM, G. B. 1952 *Commun. Pure Appl. Math.* **5**, 301.
WHITHAM, G. B. 1956 *J. Fluid Mech.* **1**, 290.
WHITHAM, G. B. 1957 *J. Fluid Mech.* **2**, 145.
WHITHAM, G. B. 1959 *J. Fluid Mech.* **5**, 369.
WOODS, B. A. 1962 *R.A.E. Tech. Note Aero.* no. 2848.

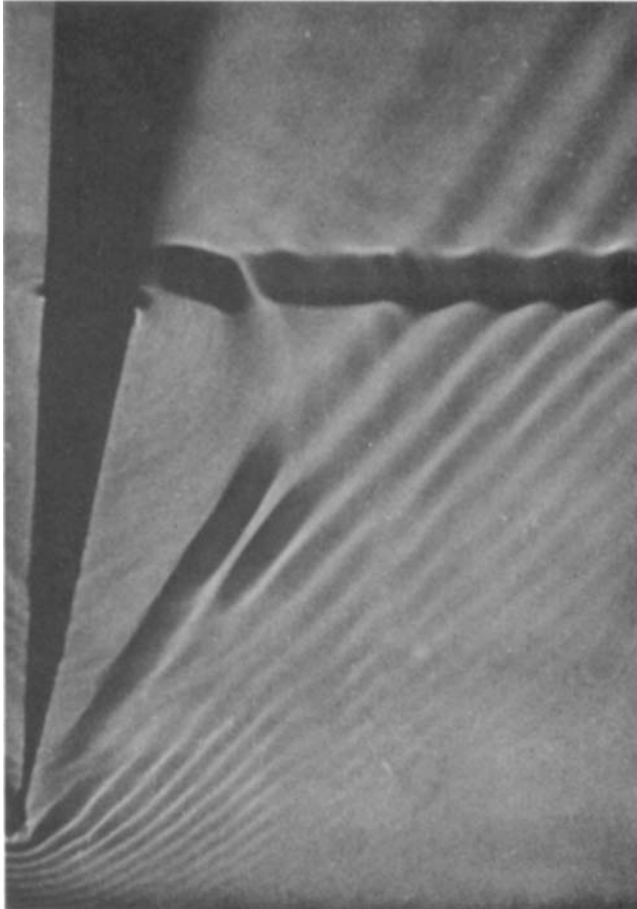

FIGURE 11. Bore meeting wedge in super-critical flow in shallow water tank. Photograph taken by E. J. Klein in the Hydraulics Laboratory, The Royal College of Science and Technology, Glasgow (Smyrl 1963).

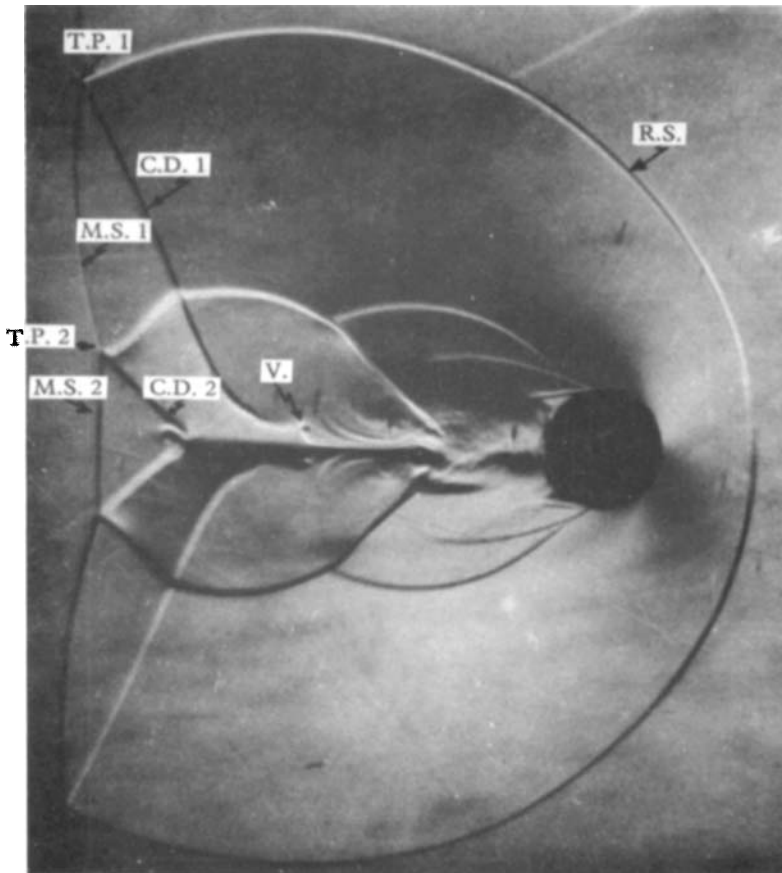

FIGURE 16. Schlieren photograph of shock diffraction on a cylinder of $\frac{1}{2}$ in. diameter; $M_0 = 2.84$. Notation: M.S., Mach shock; R.S., reflected shock; C.D., contact discontinuity; T.P., triple point; V., vortex (Bryson & Gross 1961).